

control – motion – interface

# ES 001

## Incremental Encoder Simulator



- Unit for simulation of the function of incremental encoders and scales
- Output frequency adjustable from 0 to 500 kHz
- Indexing function to generate impulse chains with a counted number of impulses
- Outputs A, /A, B, /B, Z, /Z with 5 volts TTL level or with 10 – 30 volts HTL level
- Adjustable direction of rotation (phase relation A/B)
- Programmable marker pulse distance

## Operating Instructions



## Safety Instructions

- This manual is an essential part of the unit and contains important hints about function, correct handling and commissioning. Non-observance can result in damage to the unit or the machine or even in injury to persons using the equipment!
- The unit must only be installed, connected and activated by a qualified electrician
- It is a must to observe all general and also all country-specific and application-specific safety standards
- When this unit is used with applications where failure or maloperation could cause damage to a machine or hazard to the operating staff, it is indispensable to meet effective precautions in order to avoid such consequences
- Regarding installation, wiring, environmental conditions, screening of cables and earthing, you must follow the general standards of industrial automation industry
- - Errors and omissions excepted –

Version:	Description:
ES00101a /kk/hk/Nov06	First edition

# Table of Contents

1.	Introduction .....	4
2.	Connections .....	5
2.1	TTL or HTL Output Level .....	5
2.2	Connection to Other motrona Units .....	6
3.	Display Panel and Control Panel .....	7
3.1	Display Panel .....	7
3.2	Control Panel .....	8
3.3	Operating Modes PPR, MAN and RATE .....	8
3.3.1	The PPR Mode .....	8
3.3.2	The MAN Mode .....	9
3.3.3	The RATE Mode .....	9
3.3.4	Direction Control .....	9
4.	Specifications and Dimensions .....	10

# 1. Introduction

Incremental encoders and measuring systems can be found in nearly every application of machine building industry. With consideration of this, an adequate simulator can be advantageously used for the following jobs:

- Testing of machine components or control units, without need to have all mechanical details ready and available
- „Dry testing“ during commissioning, with the machine in standstill
- Setup and inspection of electronic measuring systems, converters, counters etc. including test of cables and wiring
- Localization of error sources with malfunction and trouble-shooting

ES001 provides simulation of a wide speed range, from single step and slow motion up to encoder frequencies of 500 kHz. The unit is suitable to generate TTL and HTL level impulses with forward or reverse rotation, including a programmable zero pulse. Clearly arranged display and operator panels ensure simple and easy operation of the unit.



With simulation of encoders providing an integral part of a closed control loop, the frequency generated by the ES001 simulator will not follow the control signals of the system, which may cause irregular machine functions.

For a complete closed-loop encoder simulation, please consider our V/f-converter model UF251.

## 2. Connections

The diagram below shows the wiring of the unit via the 9-position Sub-D-connector (male connector on unit site). Assembled connection cables with female connector on one side and wires with conductor sleeves on the other side are available on request.

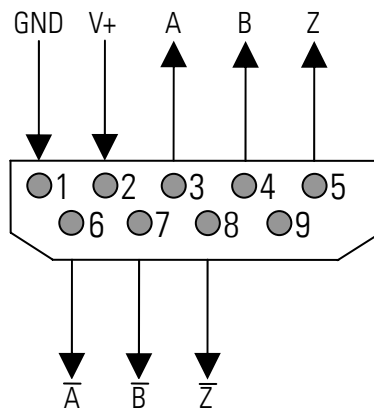

The unit accepts a power supply from 5 to 30 volts, which must be applied to pins 1 and 2 of the connector. The maximum current consumption is about 100 mA. In general, the same power source will be used which normally would also supply the encoder, but also any other remote power source is acceptable.



### Pin assignment

For technical reasons, the pin assignment of the ES001 encoder simulator diverges from the usual motrona standard pin assignments



### Indication of insufficient power supply

All LEDs will be lit at the same time when the supply voltage falls below the acceptable minimum level. When you observe this, the unit is not ready to work.

### 2.1 TTL or HTL Output Level

The square wave output swing only depends on the power supply voltage. To produce TTL outputs, the simulator must receive a 5 volts power input. To produce HTL signals, the input voltage must be accordingly higher.

The output level will always be about 1.5 volts lower than the power supply voltage.

## 2.2 Connection to other motrona units

Due to different pin assignments, the two ends of a cable with Sub-D-connectors are not interconvertible. To avoid misconnection, we recommend to either code the two connectors, or to at least mark the cable ends clearly.

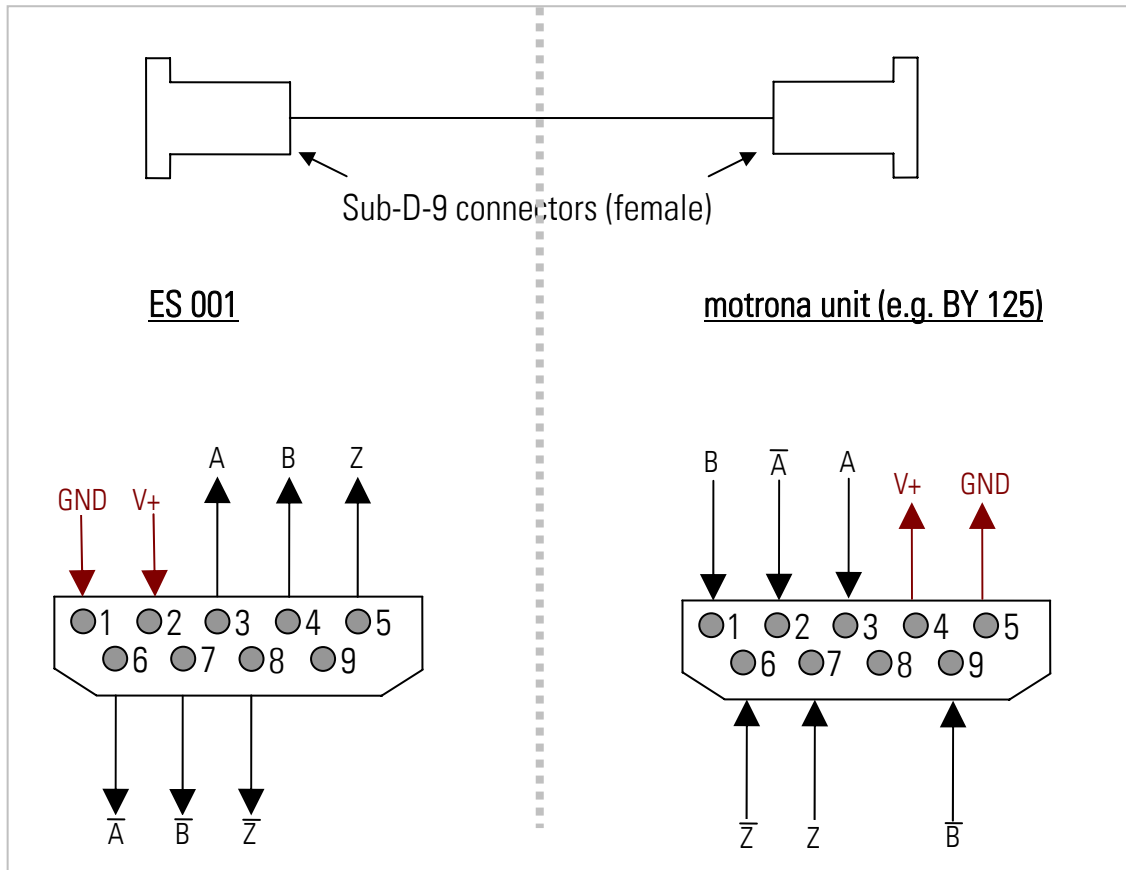

## 3. Display Panel and Control Panel

### 3.1 Display Panel

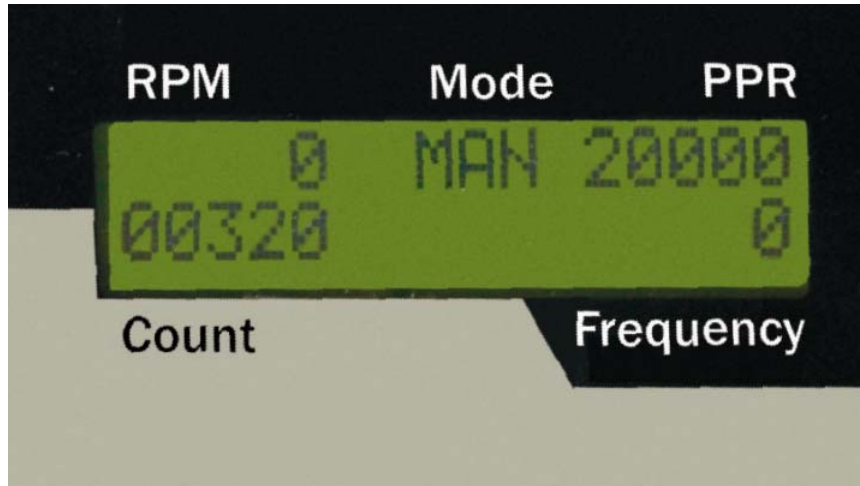

The display panel is grouped into the following 5 sections:

Section	Description	Setting Range	Display Range
RPM	Actual speed (rev./min) (= 60 * Frequency/ PPR)		0 ... 15000 ←←←←← (with overflow)
Mode	Actual operating mode	PPR, MAN, RATE	
PPR	Preset number of pulses per rev.	2 ... 99999	
Count	Number of output pulses		0 ... 99999
Frequency	Actual output frequency		40 Hz ... 500 kHz

Depending on the operation mode, the display sections may have different meanings as described under 3.3.

### 3.2 Control Panel

The control panel is grouped into the sections Mode-Selection, Direction Control and Hertz Fine Adjust

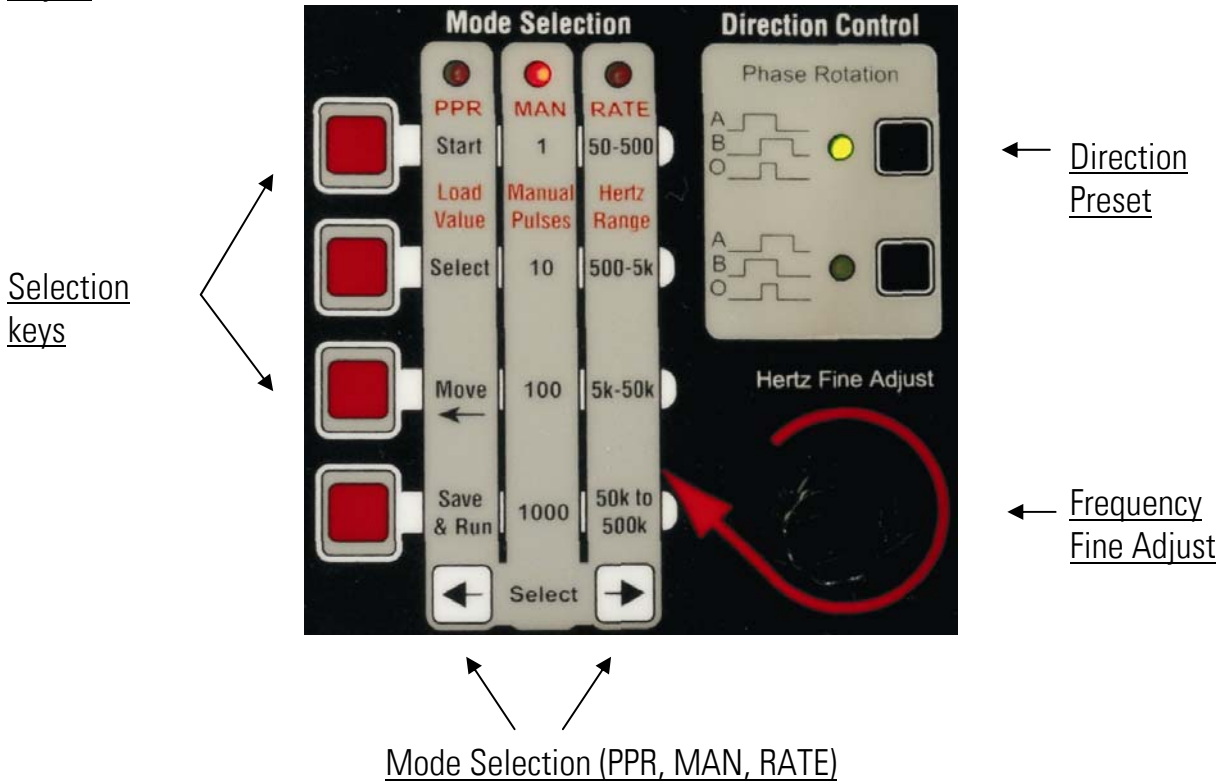

### 3.3 Operating Modes PPR, MAN and RATE

The desired operating mode can be selected by means of the two Mode Select Keys. The red LED at the top of each column shows the selected function (PPR, MAN or RATE). At the same time, the function appears in the mode section of the LCD display.

#### 3.3.1 The PPR Mode

This mode provides preselection of the desired encoder ppr number (number of encoder pulses per revolution). The setting range is from 2 to 99999. The following functions are assigned to the red selection keys:

Key	Function	Description
Start	Reset	Starts a new selection process by setting the PPR number to an initial value of 2
Select	Increment	The actual digit is incremented by 1 (loop 1, 2,..., 9, 0, 1, 2, .. etc.)
Move	Shift the digit to left	Shifts the actual digit one space to the left and automatically shifts a zero to the previous position to increment the next digit
Save & Run	Store	Stores the actual ppr setting and sets the counter in the „Count“ section to zero. The unit is ready to work.

The selected PPR number (= pulses between two marker pulses) appears in the „PPR“ section.

### 3.3.2 The MAN Mode

This mode provides the facility to manually control the number of output signals sent. The progress of this entry is displayed on the "Count" display.

Each operation of one of the red keys sends the number of output pulses indicated on the middle column of the control panel (1, 10, 100 or 1000 pulses).

The associated output frequency can beforehand be selected in the "Rate" mode.

### 3.3.3 The RATE Mode

This mode provides continuous impulse generation with the adjusted output frequency. The four red keys allow preselection of the following frequency ranges:

- 50-500: Range 50 Hz to 500 Hz,
- 500- 5k: Range 500 Hz to 5 kHz,
- 5k-50k: Range 5 kHz to 50 kHz
- 50k-500k: Range 50 kHz to 500 kHz

Speeds between the ranges can be adjusted by rotating the "Hertz Fine Adjust" knob.

The LCD display indicates the following details:

RPM	Mode	PPR
Encoder frequency (rev./min)	RATE	Number of pulses per encoder revolution
Actual count number (position) within one encoder revolution.		Output frequency
Count		Frequency

### 3.3.4 Direction Control

Two keys in the Direction Control Field provide selection of forward or reverse direction.

Pressing the upper key results in a signal with output A rising before B.

Pressing the lower key results in a signal with output B rising before A.

The selected direction is indicated by a green LED.



If none of the green LEDs is lit, this indicates that no output signal will be generated

## 4. Specifications and Dimensions

Power Supply	:	5 – 30 Vdc, max. 100 mA
Outputs	:	3 line driver output channels (push-pull) (A, /A, B, /B, Z, /Z)
Display	:	LCD display 2 lines x 16 characters 5,5 mm x 3 mm (.217 x .118")
Output frequency:	:	single step and 40 Hz – 500 kHz (4 ranges)
Connection	:	9-position Sub-D-connector (male on the unit)
Conformity and standards	:	EMC 89/336/EEC: EN 61000-6-2 EN 61000-6-3 LV73/23/EEC: EN 61010-1

